

MAINTENANCE

Engine Oil and Filter

Engine oil quality is the chief factor affecting engine service life. Change the engine oil as specified in the maintenance schedule (page 61).

NOTE:

- Change the engine oil with the engine at normal operating temperature and the motorcycle on its center stand to assure complete and rapid draining.

CAUTION:

- ***To prevent oil leaks and filter damage, never support the engine on the oil filter.***
1. To drain the oil, remove the front right side cover (page 29), then oil filler cap, drain bolt and sealing washer.

▲ WARNING

- ***A warmed-up engine and the oil in it are hot; be careful not to burn yourself.***

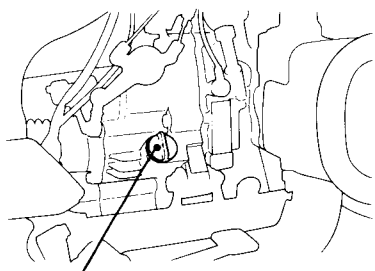

Oil Filler Cap

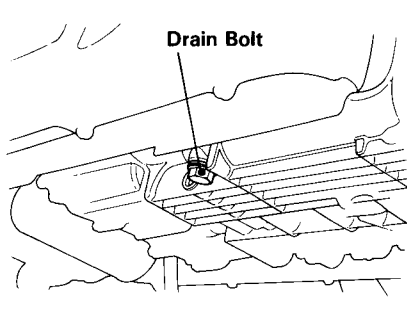

Drain Bolt