

- Connect the fuel pump red (18) and black (19) wire terminals to the fuel pump base terminals (20).
Push the wire terminals until they stop as shown.

Be careful not to damage the wires.

- Apply 0.5 g maximum of engine oil to a new O-ring (21).
Install a new O-ring onto the fuel pump unit (22).

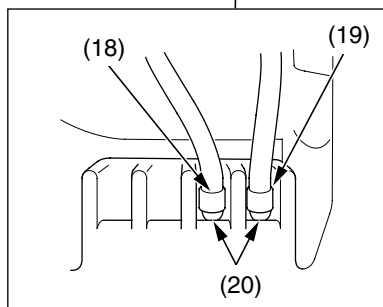
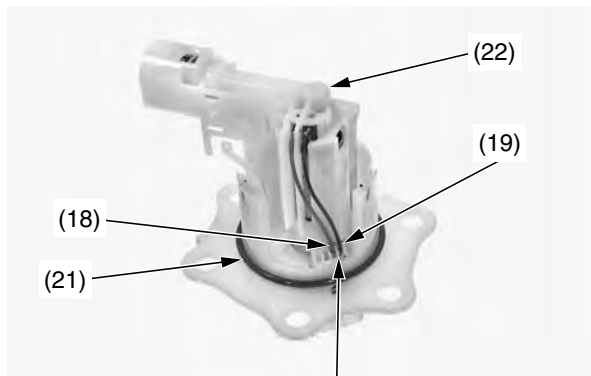

- (18) red wire terminal
- (19) black wire terminal
- (20) fuel pump base terminals
- (21) O-ring (new)
- (22) fuel pump unit

- Install a new O-ring (23) into the fuel tank groove.
- Install the fuel pump unit (24) into the fuel tank (25).

Be careful not to damage the wires.

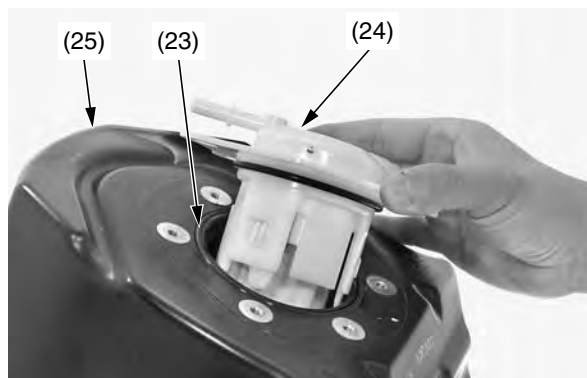

- (23) O-ring (new)
- (24) fuel pump unit
- (25) fuel tank

- Install the fuel pump plate (26) with its identification mark (27) facing toward the front side and facing up.

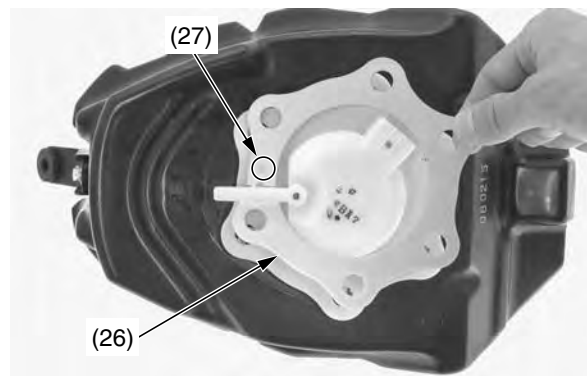

- (26) fuel pump plate
- (27) identification mark

- Install the conical spring washers (28), collars (29), washers (30), stopper cable (31), stopper cable guide (32) and fuel pump mounting bolts (33).
- Install the fuel tank.

Make sure that the convex surface of the conical spring washers are upside.

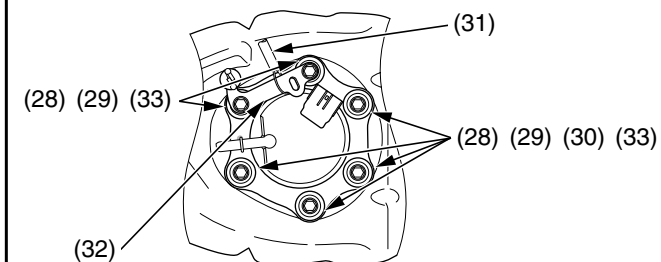

- (28) conical spring washers
- (29) collars
- (30) washers
- (31) stopper cable
- (32) stopper cable guide
- (33) fuel pump mounting bolts

- Tighten the fuel pump mounting bolts to the specified torque in the specified sequence as shown.
8 lbf-ft (11 N·m, 1.1 kgf·m)

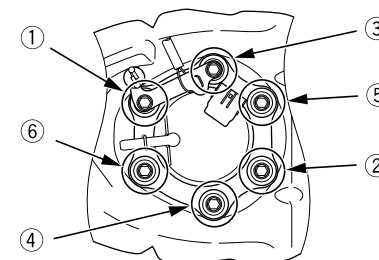

- Connect the fuel line ([page 42](#)).
- Increase the fuel pressure ([page 48](#)).