

Refer to [Safety Precautions](#) on page 23.

The service life of the chain depends on proper lubrication and adjustment. Poor maintenance can cause premature wear or damage to the drive chain or sprockets.

When the motorcycle is ridden on unusually dusty or muddy tracks, more frequent maintenance will be necessary.

Before servicing your drive chain, turn the engine OFF and check that your transmission is in neutral.

Inspection

1. Turn the engine off, raise the rear wheel off the ground by placing an optional workstand or equivalent support under the engine and shift the transmission into neutral.
2. Check the drive chain slack (1) in the upper drive chain run midway between the drive (2) and driven sprockets (3). Drive chain slack should allow the following vertical movement by hand:
1 – 1 3/8 in (25 – 35 mm)

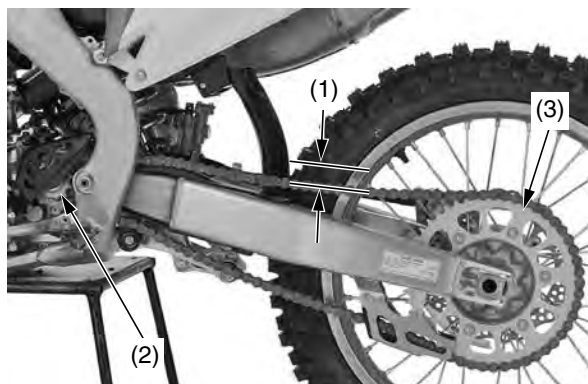

(1) drive chain slack
(2) drive sprocket
(3) driven sprocket

3. Check drive chain slack at several points along the chain. The slack should remain constant. If it isn't, some links may be kinked and binding. Lubricating the chain will often eliminate binding and kinking.

NOTICE

Excessive chain slack may allow the drive chain to damage the engine cases.

4. Inspect the drive chain for:
 - damaged rollers
 - loose pins
 - dry or rusted links
 - kinked or binding links
 - excessive wear

Replace the drive chain ([page 99](#)) if it has damaged rollers, loose pins, or kinks that cannot be free. Lubricate the drive chain ([page 98](#)) if it appears dry or shows signs of rust. Lubricate any kinked or binding links and work them free. Adjust chain slack if needed ([page 98](#)).

Drive Chain Sliders

1. Check the chain slider (1) for wear. Replace it if below the service limit.
SERVICE LIMIT:
upper side: 0.2 in (5 mm)
lower side: 0.10 in (2.5 mm)

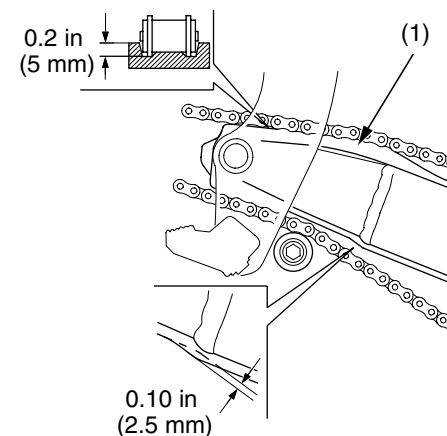

(1) chain slider

2. Check the chain guide slider (2) for wear. Replace the guide slider if it is worn to the bottom of the wear indicator (3).

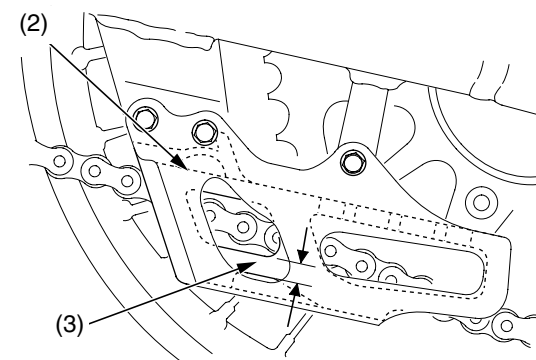

(2) chain guide slider
(3) wear indicator