

Steering Damper

Removal

1. Remove the number plate ([page 103](#)).
2. Remove the steering damper mounting bolts (1), collar (2) and steering damper (3).

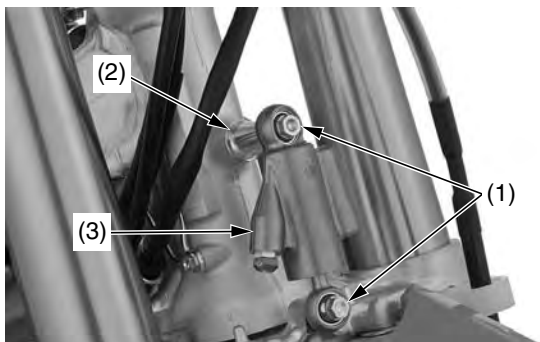

- (1) steering damper mounting bolts
(2) collar
(3) steering damper

Inspection

1. Check the damper rod (1) operation.
The damper rod is fully extended and compressed by hand. Release the damper rod, then check that it extends to its maximum length.

If the damper rod does not extend its maximum length, disassemble and inspect for steering damper.

Refer to the Honda Service Manual or see your dealer.

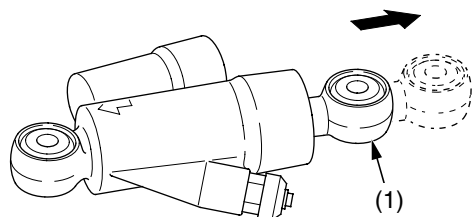

- (1) damper rod

2. Check the condition of the spherical bearings (2).
Move the spherical bearing with your finger. The spherical bearing should move smoothly and quietly.

Replace the spherical bearing if it does not move smoothly and quietly.

Refer to the Honda Service Manual or see your dealer.

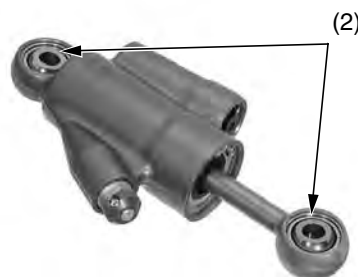

- (2) spherical bearings

Installation

1. Clean and apply a locking agent to the steering damper mounting bolt threads.
2. Install the steering damper (1) with its “UP” mark (2) facing up and forward. Turn the damper rod and its stopper ring (3) facing toward the front side.
3. Install the collar (4) and steering damper mounting bolts (5).
Be sure to install the collar with its wide flange side facing toward the steering head pipe side.
4. Tighten the steering damper mounting bolts to the specified torque:
15 lbf·ft (20 N·m, 2.0 kgf·m)

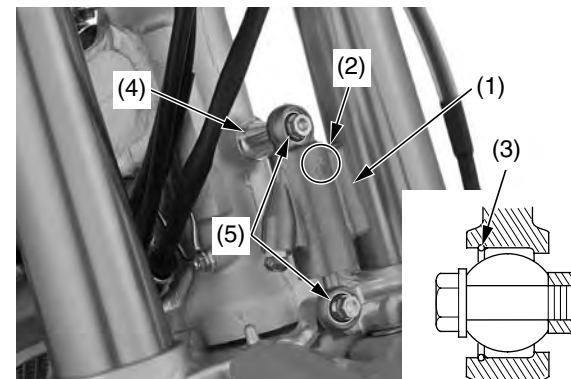

- (1) steering damper
(2) “UP” mark
(3) stopper ring
(4) collar
(5) steering damper mounting bolts

5. Place your CRF on the workstand or equivalent support with the front wheel off the ground.
Check that the steering moves smoothly from side-to-side.



6. Install the number plate ([page 103](#)).