

Front Suspension Adjustments

19. Tighten the fork damper (17) to the specified torque using the lock nut wrench (18).

Actual:

25 lbf·ft (34 N·m, 3.5 kgf·m)

Torque wrench scale reading:

23 lbf·ft (31 N·m, 3.2 kgf·m), using a 20 in (500 mm) long deflecting beam type torque wrench.

- Lock nut wrench 07WMA-KZ30100

When using the lock nut wrench, use a 20 in (500 mm) long deflecting beam type torque wrench. The lock nut wrench increases the torque wrench's leverage, so the torque wrench reading will be less than the torque actually applied to the fork damper.



(17) fork damper (18) lock nut wrench

20. For ease of releasing air pressure after the forks are installed, loosen the fork bridge lower pinch bolts and position the outer tubes so that the fork air pressure release screws are in front of the compression damping adjusters. Align the top of the outer tube (19) with the top surface of the top bridge (20).

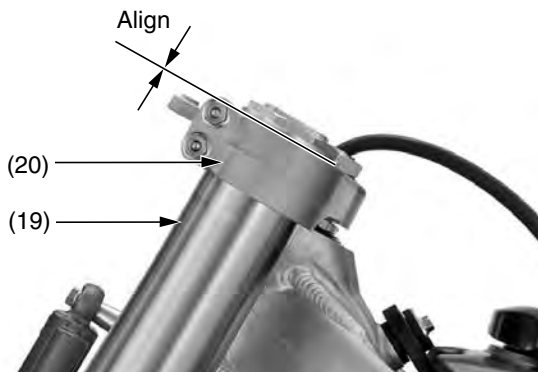

(19) outer tube (20) top bridge

21. Tighten the fork bridge lower pinch bolts (16) to the specified torque:
15 lbf·ft (20 N·m, 2.0 kgf·m)
22. Tighten the fork bridge upper pinch bolts (21) to the specified torque:
16 lbf·ft (22 N·m, 2.2 kgf·m)

NOTICE

Over-tightening the pinch bolts can deform the outer tubes. Deformed outer tubes must be replaced.

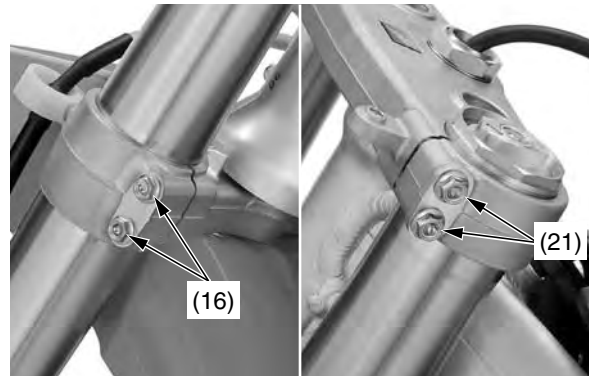

(16) fork bridge lower pinch bolts

(21) fork bridge upper pinch bolts

23. Clean the threads of the fork protector socket bolts (22) and axle holder thoroughly. Apply locking agent to the bolt threads. Install the fork protectors (23), fork protector bolts. Tighten the fork protector socket bolts to the specified torque:
5.2 lbf·ft (7 N·m, 0.7 kgf·m)

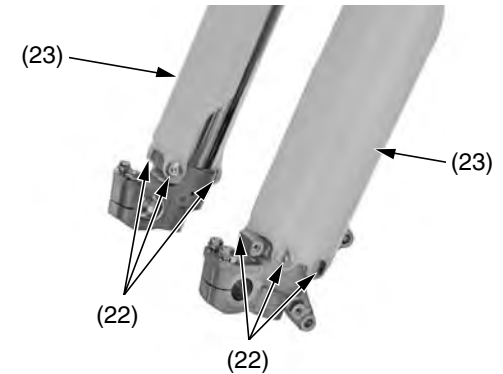

(22) fork protector socket bolts
(23) fork protectors

24. Align the brake caliper (24) and hose (25) with the left fork leg, making sure that the brake hose is not twisted. An improperly routed brake hose may rupture and cause a loss of braking efficiency.
25. Assemble the stay B (26), brake hose (25) and stay A (27). Install and tighten them to the left fork protector using the brake hose clamp bolts (28).