

9. Apply small amount of engine oil to a new O-ring (24).
Install a new O-ring into the fuel tank groove.
10. Install the fuel pump unit (25) into the fuel tank (26).

Be careful not to damage the wires.

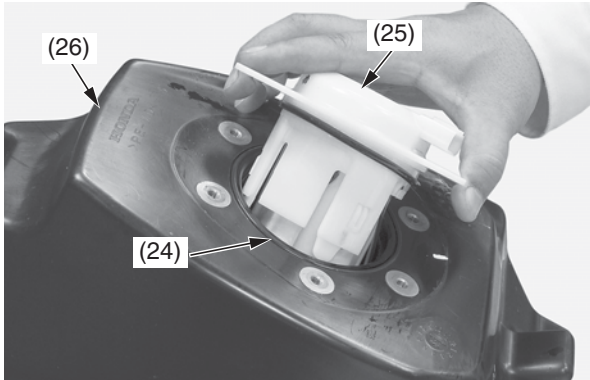

(24) O-ring (new) (26) fuel tank
(25) fuel pump unit

11. Install the fuel pump plate (27) with its identification mark (28) facing toward the front side and facing up.

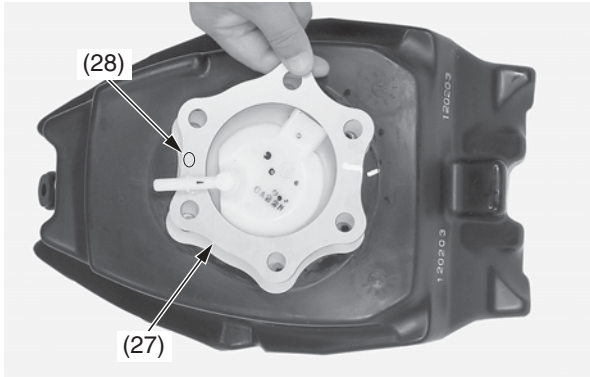

(27) fuel pump plate (28) identification mark

12. Install the conical spring washers (29), collars (30), washers (31), stopper cable (32), stopper cable guide (33) and fuel pump mounting bolts (34).

Make sure that the convex surfaces of the conical spring washers are upside.

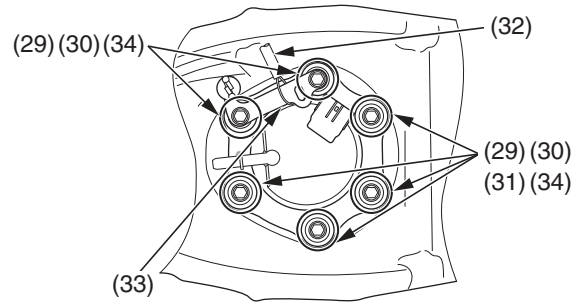

(29) conical spring washers
(30) collars
(31) washers
(32) stopper cable
(33) stopper cable guide
(34) fuel pump mounting bolts

13. Tighten the fuel pump mounting bolts to the specified torque in the specified sequence as shown:
8 lbf·ft (11 N·m, 1.1 kgf·m)

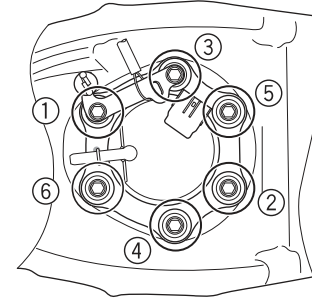

14. Connect the fuel pump connector B (35).
15. Install the stopper cable (32) to the hook (36) of the frame while holding the fuel tank (26).

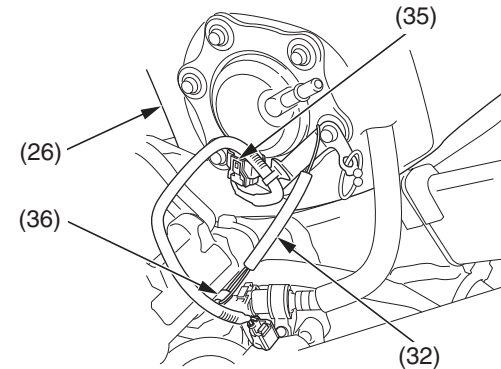

(26) fuel tank (35) fuel pump connector B
(32) stopper cable (36) frame hook

16. Connect the fuel line (page 42).
17. Increase the fuel pressure (page 48).

(cont'd)