

# Fuel System

## Fuel Pressure Increasing

Make sure the fuel remains enough (0.3 US gal (1.0 l) minimum) in the fuel tank and add fuel if necessary before increasing fuel pressure.

1. Connect the fuel pump connector A (1) and install it to the stay (2).

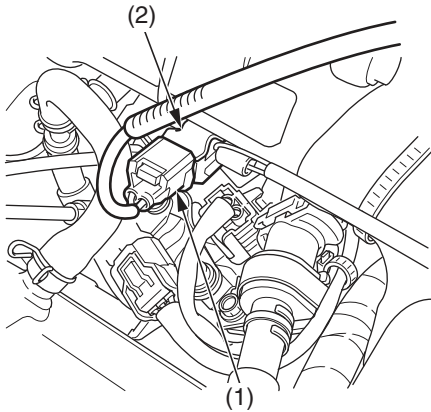

(1) fuel pump connector A (2) stay

2. Disconnect the DLC/fuel pump sub harness connector (3).

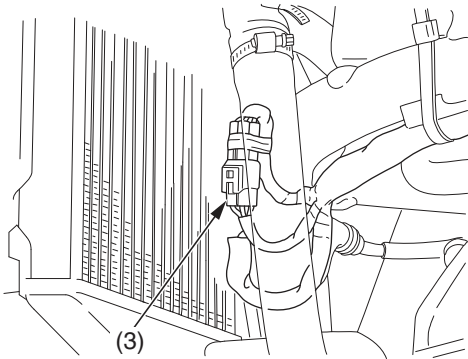

(3) DLC/fuel pump sub harness connector

3. Before connecting the battery harness cables to a 12V battery (4), make sure that the battery harness selector switches (5) are OFF.
4. Connect the battery harness positive (+) cable (6) first, then connect the battery harness negative (-) cable (7) to the terminals of a 12 V battery.
5. Connect the battery harness adaptor (8) between the battery harness (9) and the DLC/ fuel pump sub harness connectors (3) as shown.
  - Battery harness 070MZ-MEN0100
  - Battery harness adaptor 070MZ-KRN0100

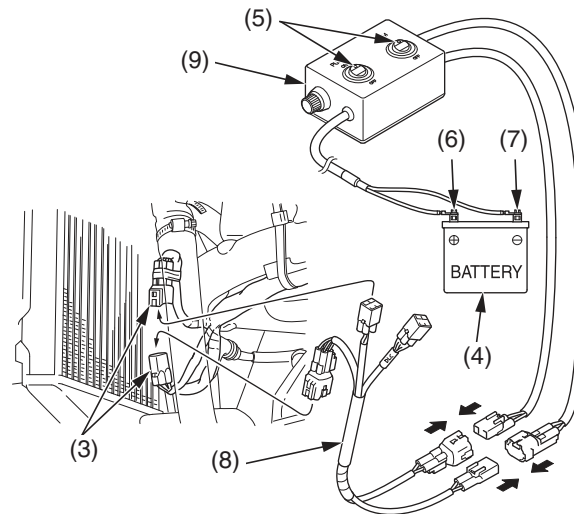

- (3) DLC/fuel pump sub harness connectors
- (4) 12 V battery
- (5) battery harness selector switches
- (6) battery harness positive (+) cable
- (7) battery harness negative (-) cable
- (8) battery harness adaptor
- (9) battery harness

6. Position the fuel tank on the main frame.
7. Turn the "PUMP" selector switch (10) ON. The selector switches can be used to change power delivery as follows:
  - "ECM" selector switch ON: Power to ECM only.
  - "PUMP" selector switch ON: Power to fuel pump only.
  - Both selector switches ON: Power to ECM and fuel pump.
8. Run the fuel pump for about 3 – 5 seconds, and fuel pressure will rise.
9. Turn the "PUMP" selector switch OFF. Check that there is no leakage in the fuel line.

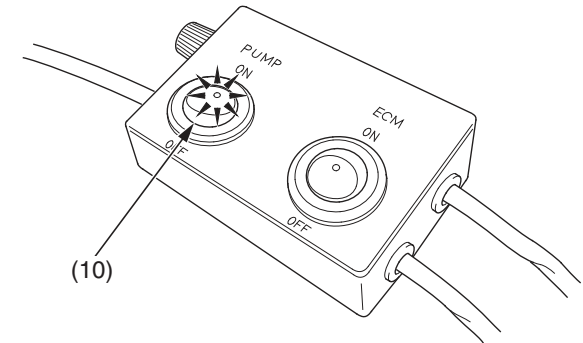

(10) "PUMP" selector switch

10. Make sure that the battery harness selector switches are OFF.
11. Disconnect the battery harness negative (-) cable from the battery first, then disconnect the battery harness positive (+) cable.
12. Remove the battery harness and battery harness adaptor.
13. Connect the DLC/fuel pump sub harness connectors.
14. Install the fuel tank ([page 36](#)).