

Front Suspension Adjustments

7. Apply fork oil to the fork cap bushings (6), new O-rings (7) and piston ring (8) on the fork cap assembly (1).

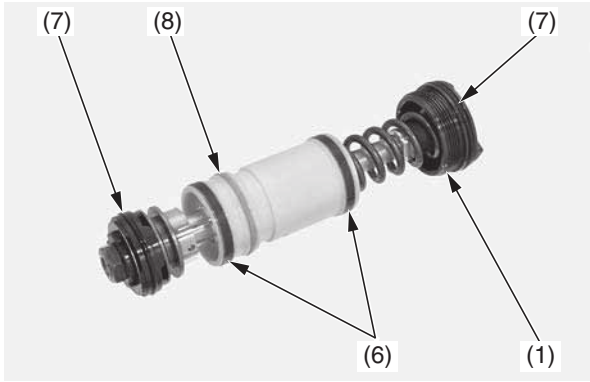

(1) fork cap assembly
(6) fork cap bushings
(7) O-rings (new)
(8) piston ring

8. Cover the oil holes by hand. Extend the fork damper piston rod (2) to 0.8 in (20 mm), holding it, install the fork cap assembly (1) to the fork damper (5) while extending the damper piston rod with vertical position.

Be careful not to damage the fork cap bushings. If it is difficult to install the fork cap assembly, the fork damper oil level might be higher than standard oil level.

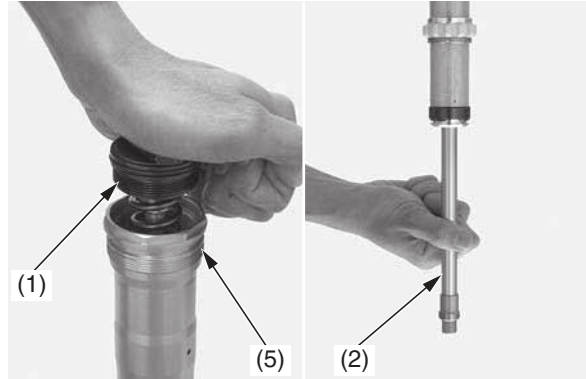

(1) fork cap assembly
(2) fork damper piston rod
(5) fork damper

9. Completely screw in the fork center bolt lock nut (9) to the fork damper piston rod (2).

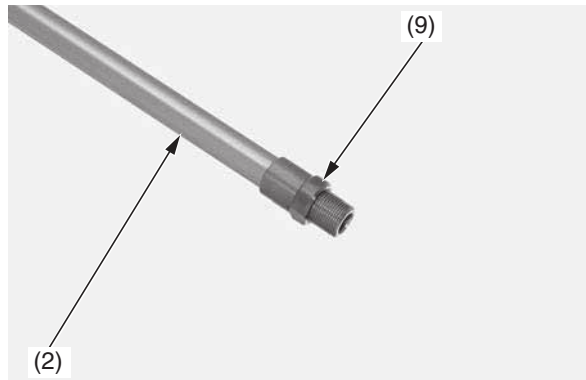

(2) fork damper piston rod (9) fork center bolt lock nut

10. Check the fork damper piston rod sliding surface for damage.
11. Cover the fork damper piston rod end with shop towel (10) to prevent fork damage. Hold the fork damper in an upright position and pump the fork damper piston rod (2) to 3.9 in (100 mm) slowly several times.
12. Cover the oil holes (11) with shop towel to prevent blow out of fork oil. Blow the extra oil off from the fork damper oil chamber (3) by pumping the fork damper piston rod to full stroke.

NOTICE

Be careful not to bend or damage the fork damper piston rod when the piston rod is stroked.

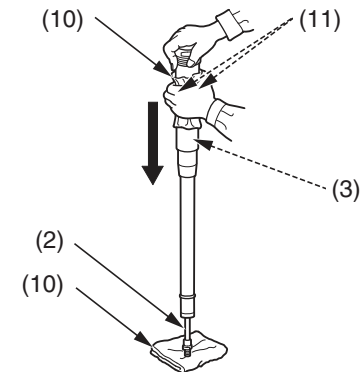

(2) fork damper piston rod
(3) fork damper oil chamber
(10) shop towel
(11) oil holes