

13. Remove the fork damper from the fork assembly (1).
  14. Pour the recommended fork oil (8) into the fork assembly.
- Recommended Oil: HP Fork Oil, SS-19

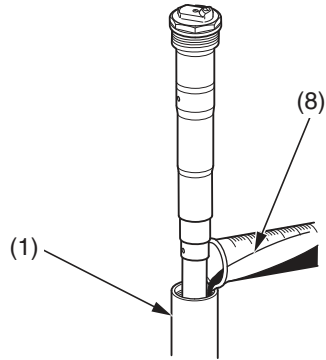

(1) fork assembly (8) fork oil

### Fork Oil Capacity:

|                       |                                   |
|-----------------------|-----------------------------------|
| Standard oil capacity | 11.8 US oz (350 cm <sup>3</sup> ) |
|-----------------------|-----------------------------------|

Approximately 0.2 US oz (7 cm<sup>3</sup>) of fork oil remains after draining. This amount must be noted when filling to the standard oil capacity.

15. Install a new O-ring (9) on the fork damper assembly (3). Apply the recommended fork oil to the O-ring.
16. Pull up the fork assembly (1) slowly and install the fork damper assembly into the outer tube.

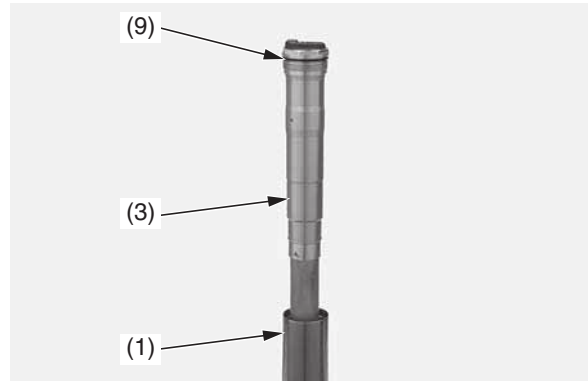

(1) fork assembly (3) fork damper assembly (9) O-ring (new)

17. Clean the threads of the fork protector socket bolts (10) and axle holder thoroughly. Apply locking agent to the bolt threads. Install the fork protector (11) and fork protector socket bolts. Tighten the fork protector socket bolts to the specified torque:  
5.2 lbf·ft (7 N·m, 0.7 kgf·m)

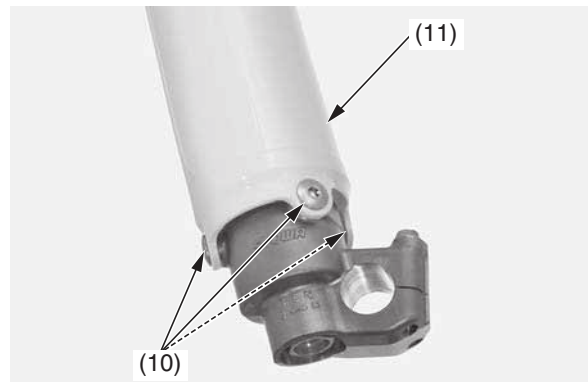

(10) fork protector socket bolts (11) fork protector

### Fork Installation

1. Insert both fork legs into the fork clamps. Tighten the fork bridge lower pinch bolts (1) to the specified torque:  
15 lbf·ft (20 N·m, 2.0 kgf·m)



(1) fork bridge lower pinch bolts

(cont'd)