

Suspension

- Place the lower end (axle holder) (7) of the slider in a vise with a piece of wood or soft jaws to avoid damage.

NOTICE

Over-tightening the vise can damage the axle holder.

- Remove the fork center bolt (13).

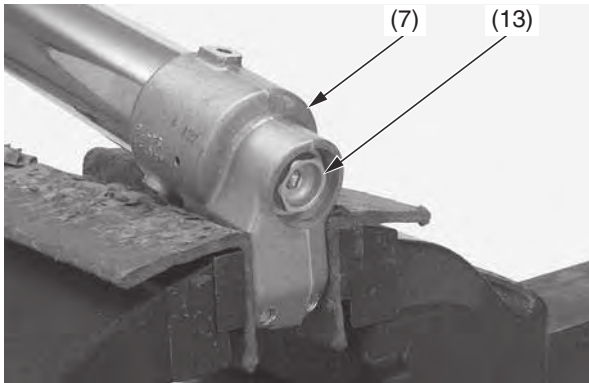

(7) axle holder (13) fork center bolt

- Push the fork center bolt (13) out from the axle holder (7) of the slider by sliding the outer tube.
- Hold the fork center bolt lock nut (14) and remove the fork center bolt from the fork damper.

NOTICE

Do not remove the lock nut from the fork damper piston rod. If the lock nut is removed, the piston rod will fall in the fork damper and you may not reassemble the fork damper.

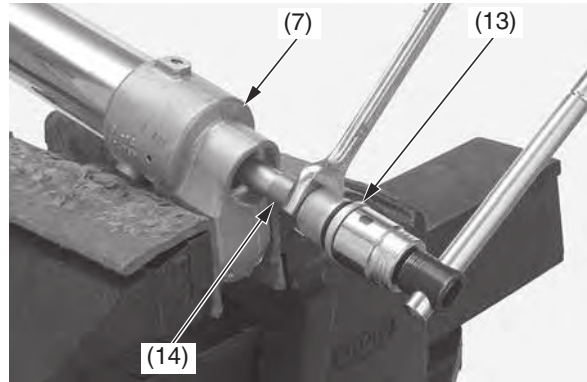

(7) axle holder (14) fork center bolt lock nut
(13) fork center bolt

- Remove the push rod (15) from the fork damper piston rod.

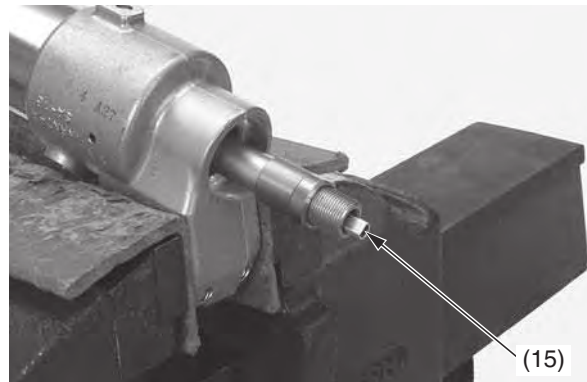

(15) push rod

- Remove the fork damper assembly (16) from the fork assembly (17). Remove the fork from the vise. Remove the O-ring (18) from the fork damper assembly.

NOTICE

Do not attempt to separate the fork assembly and drop the axle holder out from the outer tube, which can damage the guide bushings (19). To avoid damage, hold both the outer tube and slider.

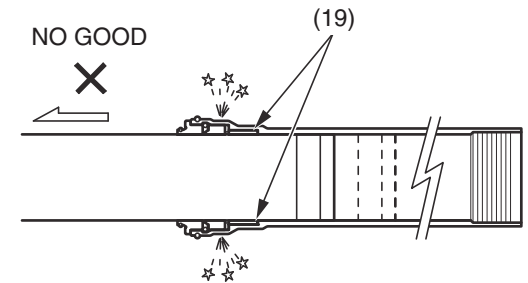

(19) guide bushing

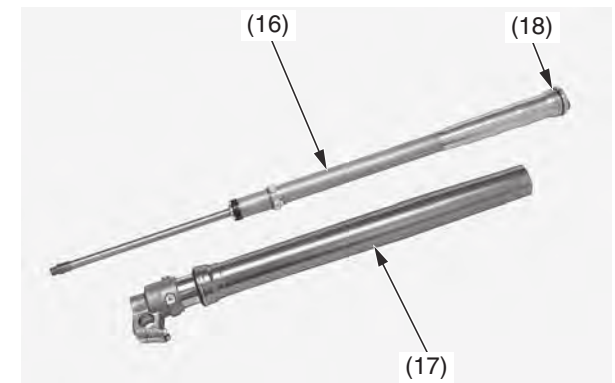

(16) fork damper assembly
(17) fork assembly
(18) O-ring