

Suspension

- Bleed the fork oil from the balance chamber air valve (5) by pumping the outer tube (7) several times.
- Install the valve center (6) of the balance chamber air valve.

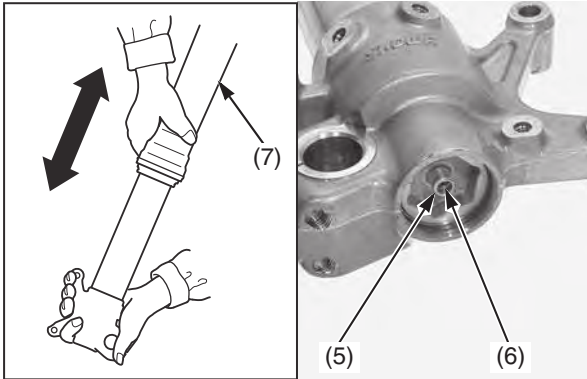

- (5) balance chamber air valve
 (6) balance chamber air valve center
 (7) outer tube

- Apply air pressure to the inner chamber through the inner chamber air valve (3) and check that there is no air leakage. Install the valve cap.

- Air fork pump 07AMJ-KRNA100 (USA only)
- Air fork pump adapter 07AMJ-KRNA110 (USA only)

Inner Chamber Air Pressure:

Standard	156 psi (1,075 kPa, 11.0 kgf/cm ²)
Maximum	170 psi (1,175 kPa, 12.0 kgf/cm ²)
Minimum	141 psi (975 kPa, 9.9 kgf/cm ²)

When applying air pressure to the inner chamber, the fork will be extended.

- Apply air pressure to the outer chamber through the outer chamber air valve (4) and check that there is no air leakage. Install the valve cap.

- Air fork pump 07AMJ-KRNA100 (USA only)
- Air fork pump adapter 07AMJ-KRNA110 (USA only)

Outer Chamber Air Pressure:

Standard	12 psi (80 kPa, 0.8 kgf/cm ²)
Maximum	15 psi (100 kPa, 1.0 kgf/cm ²)
Minimum	9 psi (60 kPa, 0.6 kgf/cm ²)

When applying air pressure to the outer chamber, the fork will be extended.

- Apply air pressure to the balance chamber through the balance chamber air valve (5) and check that there is no air leakage.

- Air fork pump 07AMJ-KRNA100 (USA only)
- Air fork pump adapter 07AMJ-KRNA110 (USA only)

Balance Chamber Air Pressure:

Standard	156 psi (1,075 kPa, 11.0 kgf/cm ²)
Maximum	189 psi (1,300 kPa, 13.3 kgf/cm ²)
Minimum	131 psi (900 kPa, 9.2 kgf/cm ²)

When applying air pressure to the balance chamber, the fork will be shortened.

- Install and tighten the balance chamber valve cap to the specified torque:
 0.4 lbf·ft (0.5 N·m, 0.1 kgf·m)

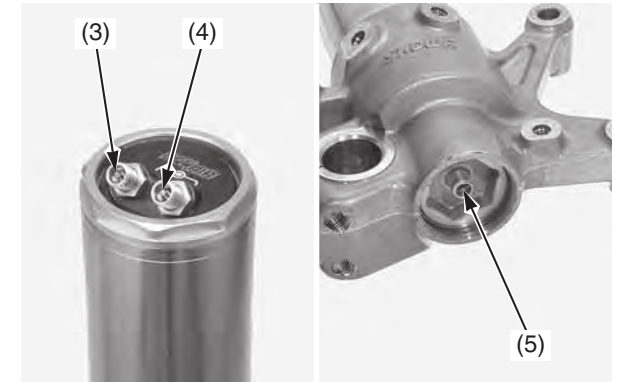

- (3) inner chamber air valve
 (4) outer chamber air valve
 (5) balance chamber air valve

- Clean the threads of the fork protector socket bolts (1) and axle holder thoroughly. Apply locking agent to the bolt threads. Install the fork protector (2) and fork protector socket bolts. Tighten the fork protector socket bolts to the specified torque:
 5.2 lbf·ft (7 N·m, 0.7 kgf·m)

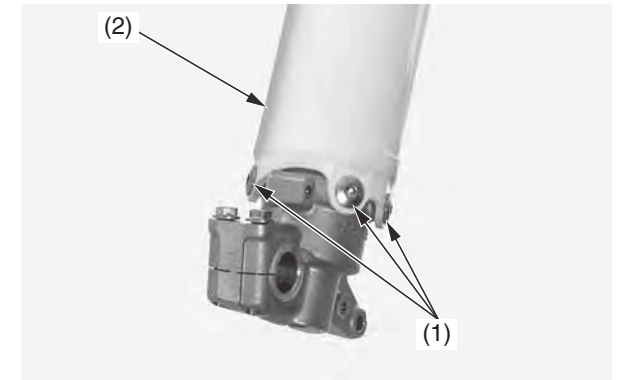

- (1) fork protector socket bolts
 (2) fork protector