

CRANKSHAFT • PISTON

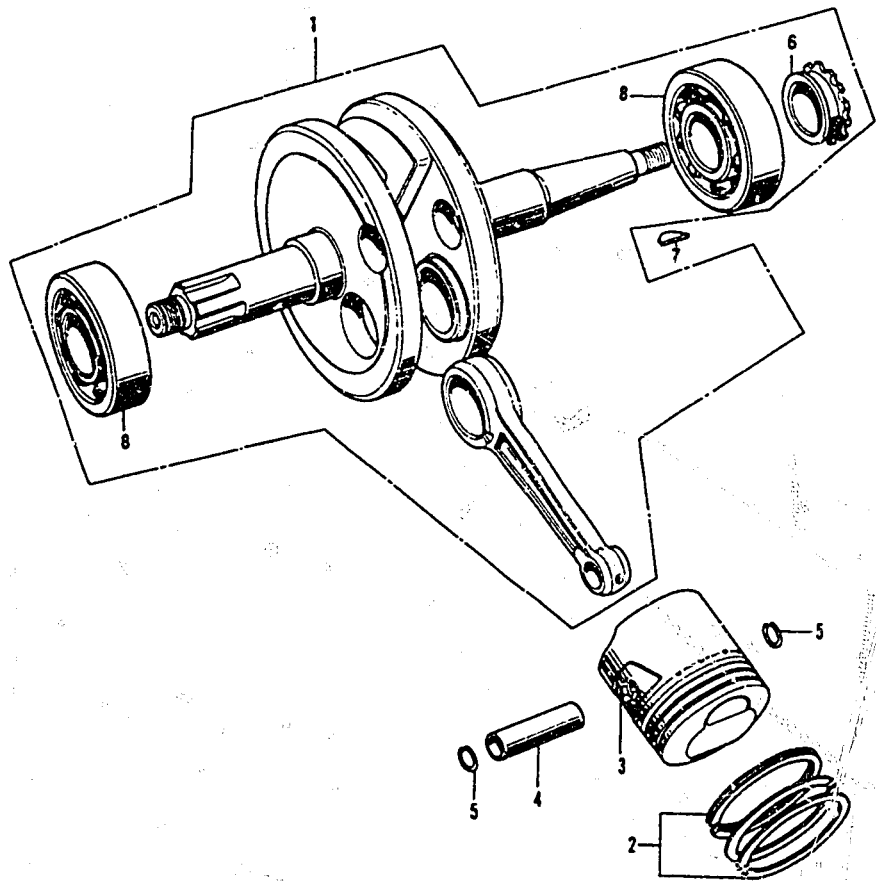

E23098008

K1 - CT70K1
K2 - CT70K2

Ref. No.	BLOCK NO. DESCRIPTION	CT70		ENGINE SERIAL NUMBER		QTY	PART NUMBER	HONDA CODE
		K1	K2	FROM	TO			
1	CRANKSHAFT COMP.	K1	K2	----	----	1	13000-098-000	0114702
2	RING SET, PISTON (STD) (NIPPON)	K1	K2	----	----	1	13010-087-003	0185322
	RING SET, PISTON (STD) (RIKEN)	K1	K2	----	----	1	13010-087-004	0287730
	RING SET, PISTON (STD) (NIPPON)	K1	K2	----	----	1	13010-087-013	1076330
	RING SET, PISTON (STD) (NIPPON)	K1	K2	----	----	1	13010-087-014	1076348
	RING SET, PISTON (STD) (NIPPON)	K1	K2	----	----	1	13010-087-023	0801894
	RING SET, PISTON (STD) (NIPPON)	K1	K2	----	----	1	13010-087-024	0834416
	RING SET, PISTON (STD) (NIPPON)	K1	K2	----	----	1	13011-087-003	0744367
	RING SET, PISTON (0.25) (NIPPON)	K1	K2	----	----	(1)	13020-087-003	0185330
	RING SET, PISTON (0.25) (RIKEN)	K1	K2	----	----	(1)	13020-087-004	0287748
	RING SET, PISTON (0.25) (NIPPON)	K1	K2	----	----	(1)	13020-087-013	1076355
	RING SET, PISTON (0.25) (NIPPON)	K1	K2	----	----	(1)	13020-087-014	1076363
	RING SET, PISTON (0.25) (NIPPON)	K1	K2	----	----	(1)	13020-087-023	0801902
	RING SET, PISTON (0.25) (NIPPON)	K1	K2	----	----	(1)	13020-087-024	0834424
	RING SET, PISTON (0.25) (NIPPON)	K1	K2	----	----	(1)	13021-087-003	0744383
	RING SET, PISTON (0.50) (NIPPON)	K1	K2	----	----	(1)	13030-087-003	0185348
	RING SET, PISTON (0.50) (RIKEN)	K1	K2	----	----	(1)	13030-087-004	0287755
	RING SET, PISTON (0.50) (NIPPON)	K1	K2	----	----	(1)	13030-087-013	0918342
	RING SET, PISTON (0.50) (NIPPON)	K1	K2	----	----	(1)	13030-087-014	1076371
	RING SET, PISTON (0.50) (NIPPON)	K1	K2	----	----	(1)	13030-087-023	0801910
	RING SET, PISTON (0.50) (NIPPON)	K1	K2	----	----	(1)	13030-087-024	0834432
	RING SET, PISTON (0.50) (NIPPON)	K1	K2	----	----	(1)	13031-087-003	0746214
	RING SET, PISTON (0.75) (NIPPON)	K1	K2	----	----	(1)	13040-087-003	0185355
	RING SET, PISTON (0.75) (RIKEN)	K1	K2	----	----	(1)	13040-087-004	0287763
	RING SET, PISTON (0.75) (NIPPON)	K1	K2	----	----	(1)	13040-087-013	0791855
	RING SET, PISTON (0.75) (NIPPON)	K1	K2	----	----	(1)	13040-087-023	0813097
	RING SET, PISTON (1.00) (NIPPON)	K1	K2	----	----	(1)	13050-087-003	0185363
	RING SET, PISTON (1.00) (RIKEN)	K1	K2	----	----	(1)	13050-087-004	0287771
	RING SET, PISTON (1.00) (NIPPON)	K1	K2	----	----	(1)	13050-087-013	0844175
	RING SET, PISTON (1.00) (RIKEN)	K1	K2	----	----	(1)	13050-087-014	1076397
	RING SET, PISTON (1.00) (RIKEN)	K1	K2	----	----	(1)	13050-087-023	0901928
	RING SET, PISTON (1.00) (RIKEN)	K1	K2	----	----	(1)	13050-087-024	0834457

CONTENTS

TITLE	PAGE	GRID
AIR CLEANER	60	D11
ALTERNATOR	10	B5
BATTERY	88	F1
BRAKE PEDAL	80	E9
CAM CHAIN TENSIONER	14	B7
CAMSHAFT	8	B4
CARBURETOR	38	C7
CHAIN CASE	78	E8
CHANGE PEDAL	98	F6
CLUTCH	18	B9
CRANKCASE	34	C5
CRANKCASE COVER L	10	B5
CRANKCASE COVER R	16	B8
CRANKCASE PROTECTOR	92	F3
CRANKSHAFT	22	B11
CYLINDER	6	B3
CYLINDER HEAD	6	B3
CYLINDER HEAD COVER	2	B1
FENDER, FR	46	D4
FENDER, RR	84	C11
FORK, FR	50	D6
FRAME	92	F3
FUEL TANK	64	E1
GEARSHIFT	26	C1
HANDLEBAR	40	D1
HEADLIGHT	44	D3
HORN	46	D4
INLET PIPE	2	B1
KICK ARM	98	F6
KICK STARTER	32	C4
MUFFLER	66	E2
OIL PUMP	34	C5
PISTON	22	B11
SEAT	60	D11
SHOCK ABSORBER, RR	76	E7
SIDE STAND	80	E9
SPARK PLUG	2	B1
SPEEDOMETER	44	D3
STEERING STEM	46	D4
STEP	80	E9
SWINGARM	76	E8
TAILLIGHT	64	E11
TOOL SET	96	F5
TRANSMISSION	30	C3
VALVE	8	B4
WHEEL, FR	54	D8
WHEEL, RR	70	E4
WIRE HARNESS	88	F1

22 AMERICAN HONDA MOTOR CO., LTD. 1993
 CT70K1 ENGINE NO.; CT70E-2000001 TO SUBSEQUENT
 CT70K1 FRAME NO.; CT70-2000001 TO SUBSEQUENT
 CT70K2 ENGINE NO.; CT70E-2100001 TO SUBSEQUENT
 CT70K2 FRAME NO.; CT70-2100001 TO SUBSEQUENT