

CRANKSHAFT • PISTON

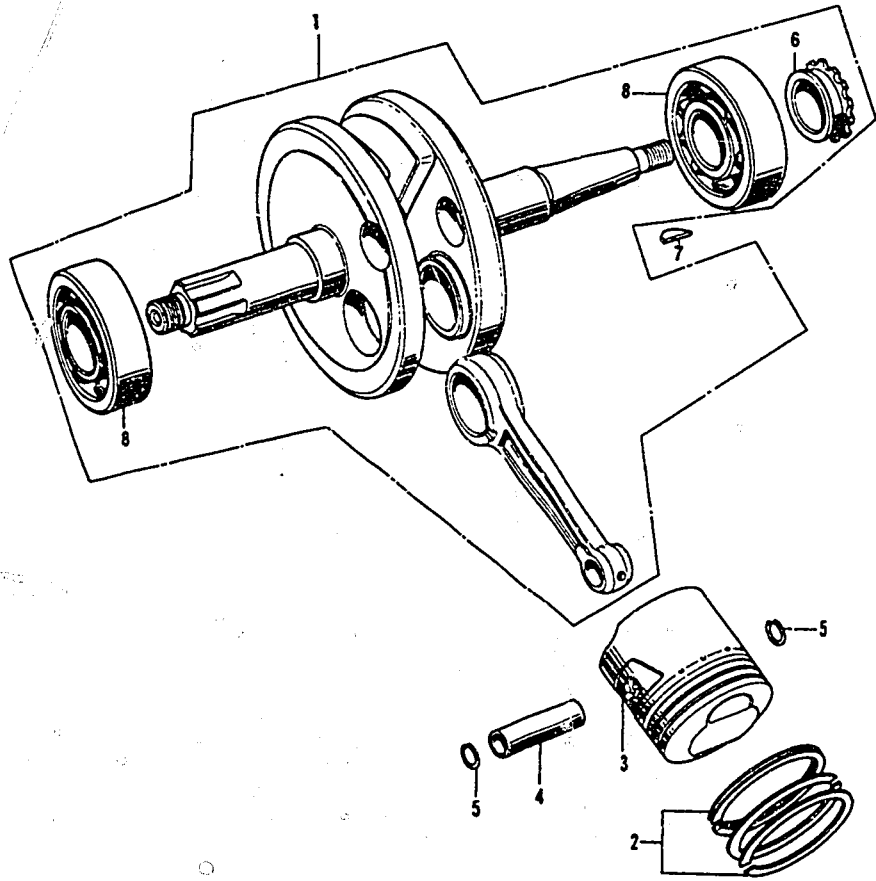

E23098008

K1 = CT70K1
K2 = CT70K2

Ref. No.	BLOCK NO. DESCRIPTION	CT70		ENGINE SERIAL NUMBER		QTY REQ	PART NUMBER	HONDA CODE
		K 1	K 2	FROM	TO			
3	PISTON (STD)	K1	K2	---	---	1	13101-087-000	0185371
	PISTON (STD)	K1	K2	---	---	1	13101-087-712	0807867
	PISTON (0.25)	K1	K2	---	---	(1)	13102-087-000	0185389
	PISTON (0.25)	K1	K2	---	---	(1)	13102-087-710	0916429
	PISTON (0.25)	K1	K2	---	---	(1)	13102-087-711	0793174
	PISTON (0.25)	K1	K2	---	---	(1)	13102-087-712	0844167
	PISTON (0.50)	K1	K2	---	---	(1)	13103-087-000	0185397
	PISTON (0.50)	K1	K2	---	---	(1)	13103-087-710	0918334
	PISTON (0.50)	K1	K2	---	---	(1)	13103-087-712	0856567
	PISTON (0.75)	K1	K2	---	---	(1)	13104-087-000	0185405
	PISTON (0.75)	K1	K2	---	---	(1)	13104-087-712	0834184
	PISTON (1.00)	K1	K2	---	---	(1)	13105-087-000	0185413
	PISTON (1.00)	K1	K2	---	---	(1)	13105-087-710	0771477
	PISTON (1.00)	K1	K2	---	---	(1)	13105-087-711	0771238
	PISTON (1.00)	K1	K2	---	---	(1)	13105-087-712	0844209
4	PIN, PISTON	K1	K2	---	---	1	13111-6B0-910	1099092
	PIN, PISTON	K1	K2	---	---	1	13111-087-000	0185421
5	CLIP, PISTON PIN	K1	K2	---	---	2	13115-001-000	0001479
	CLIP, PISTON PIN, 13MM	K1	K2	---	---	2	94601-13000	0207563
6	SPROCKET, TIMING (14T)	K1	K2	---	---	1	14311-035-000	0069765
7	KEY, WOODRUFF, 3X5	K1	K2	---	---	1	90741-035-000	0070896
8	BEARING, RADIAL BALL, 6304	K1	K2	---	---	2	96100-63040	0053363
	BEARING, RADIAL BALL, 6304	K1	K2	---	---	2	96100-63040-00	0341644

B12

CONTENTS

TITLE	PAGE	GRID
AIR CLEANER	60	D11
ALTERNATOR	10	B5
BATTERY	88	F1
BRAKE PEDAL	80	E9
CAM CHAIN TENSIONER	14	B7
CAMSHAFT	8	B4
CARBURETOR	38	C7
CHAIN CASE	78	E8
CHANGE PEDAL	98	F6
CLUTCH	18	B9
CRANKCASE	34	C5
CRANKCASE COVER, L	10	B5
CRANKCASE COVER, R	16	B8
CRANKCASE PROTECTOR	92	F3
CRANKSHAFT	22	B11
CYLINDER	6	B3
CYLINDER HEAD	6	B3
CYLINDER HEAD COVER	2	B1
FENDER, FR	46	D4
FENDER, RR	84	E11
FORK, FR	50	D6
FRAME	92	F3
FUEL TANK	64	E1
GEARSHIFT	26	C1
HANDLEBAR	40	D1
HEADLIGHT	44	D3
HORN	46	D4
INLET PIPE	2	B1
KICK ARM	98	F6
KICK STARTER	32	C4
MUFFLER	66	E2
OIL PUMP	34	C5
PISTON	22	B11
SEAT	60	D11
SHOCK ABSORBER, RR	76	E7
SIDE STAND	80	E9
SPARK PLUG	2	B1
SPEEDOMETER	44	D3
STEERING STEM	46	D4
STEP	80	E9
SWINGARM	78	E8
TAILLIGHT	84	E11
TOOL SET	96	F5
TRANSMISSION	30	C3
VALVE	6	B4
WHEEL, FR	54	D8
WHEEL, RR	70	E4
WIRE HARNESS	88	F1

GRID

B12

CT70K1 ENGINE NO.; CT70E-2000001 TO SUBSEQUENT
 CT70K1 FRAME NO.; CT70-2000001 TO SUBSEQUENT
 CT70K2 ENGINE NO.; CT70E-2100001 TO SUBSEQUENT
 CT70K2 FRAME NO.; CT70-2100001 TO SUBSEQUENT