

STEERING STEM • FRONT FENDER • HORN

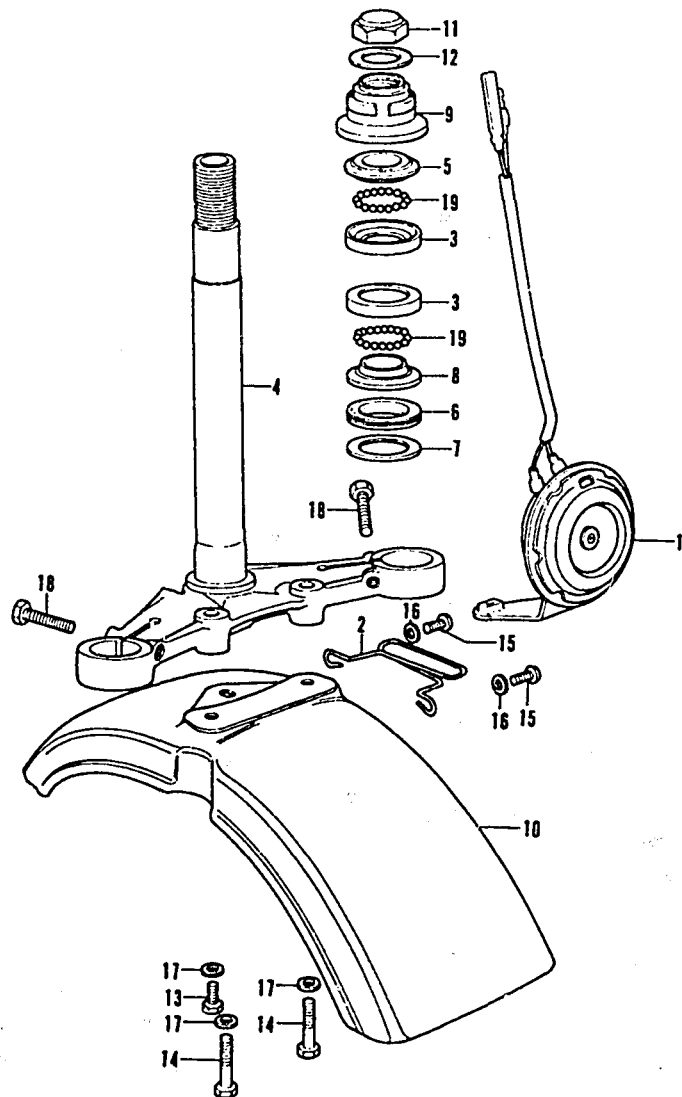

F23098003

K1 = CT70K1
K2 = CT70K2

Ref. No.	BLOCK NO. DESCRIPTION	CT70		FRAME SERIAL NUMBER		QTY REQ	PART NUMBER	HONDA CODE
		K1	K2	FROM	TO			
		1	2					
16	WASHER, PLAIN, 5MM	K1	K2	-----	-----	2	94101-05000	0059055
17	WASHER, PLAIN, 6MM	K1	K2	-----	-----	3	94101-06000	0059071
	WASHER, PLAIN, 6MM	K1	K2	-----	-----	3	94101-06080	3136074
	WASHER, PLAIN, 6MM	K1	K2	-----	-----	3	94101-06800	0345900
18	BOLT, HEX., 8X28	K1	K2	-----	-----	2	95400-08028-00	0698480
19	BALL, STEEL, =6 (3/16)	K1	K2	-----	-----	42	96211-06000	0058925

CONTENTS

TITLE	PAGE	GRID
AIR CLEANER	60	D11
ALTERNATOR	10	B5
BATTERY	88	F1
BRAKE PEDAL	80	E9
CAM CHAIN TENSIONER	14	B7
CAMSHAFT	8	B4
CARBURETOR	38	C7
CHAIN CASE	78	E8
CHANGE PEDAL	98	F6
CLUTCH	18	B9
CRANKCASE	34	C5
CRANKCASE COVER, L	10	B5
CRANKCASE COVER, R	16	B8
CRANKCASE PROTECTOR	92	F3
CRANKSHAFT	22	B11
CYLINDER	6	B3
CYLINDER HEAD	6	B3
CYLINDER HEAD COVER	2	B1
FENDER, FR	46	D4
FENDER, RR	84	E11
FORK, FR	50	D6
FRAME	92	F3
FUEL TANK	64	E1
GEARSHIFT	26	C1
HANDLEBAR	40	D1
HEADLIGHT	44	D3
HORN	46	D4
INLET PIPE	2	B1
KICK ARM	98	F6
KICK STARTER	32	C4
MUFFLER	66	E2
OIL PUMP	34	C5
PISTON	22	B11
SEAT	60	D11
SHOCK ABSORBER, RR	76	E7
SIDE STAND	80	E9
SPARK PLUG	2	B1
SPEEDOMETER	44	D3
STEERING STEM	46	D4
STEP	80	E9
SWINGARM	78	E8
TAILLIGHT	84	E11
TOOL SET	96	F5
TRANSMISSION	30	C3
VALVE	8	B4
WHEEL, FR	54	D8
WHEEL, RR	70	E4
WIRE HARNESS	80	F1

GRID **D5**

48 AMERICAN HONDA MOTOR CO., LTD. 1993
 CT70K1 ENGINE NO.; CT70E-2000001 TO SUBSEQUENT
 CT70K1 FRAME NO.; CT70-2000001 TO SUBSEQUENT
 CT70K2 ENGINE NO.; CT70E-2100001 TO SUBSEQUENT
 CT70K2 FRAME NO.; CT70-2100001 TO SUBSEQUENT

49 AMERICAN HONDA MOTOR CO., LTD. 1993