

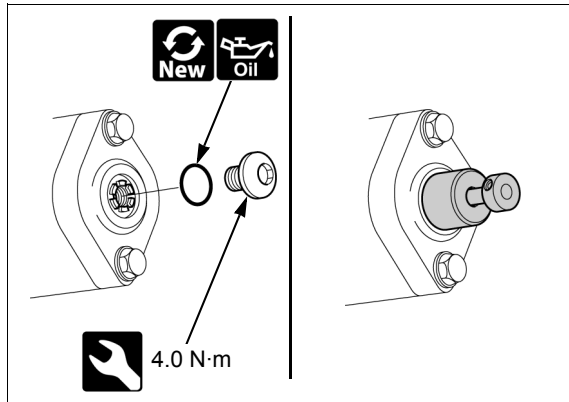

## CAMSHAFT/ROCKER ARM



- Set the piston to the TDC on the compression stroke. →2-15
- Install the special tool into the tensioner body and turn the tool clockwise until it stops. Hold the tensioner lifter by pushing the tool while aligning the tabs of the tool with the grooves of the tensioner lifter.

**Tensioner stopper: 070MG-0010100**

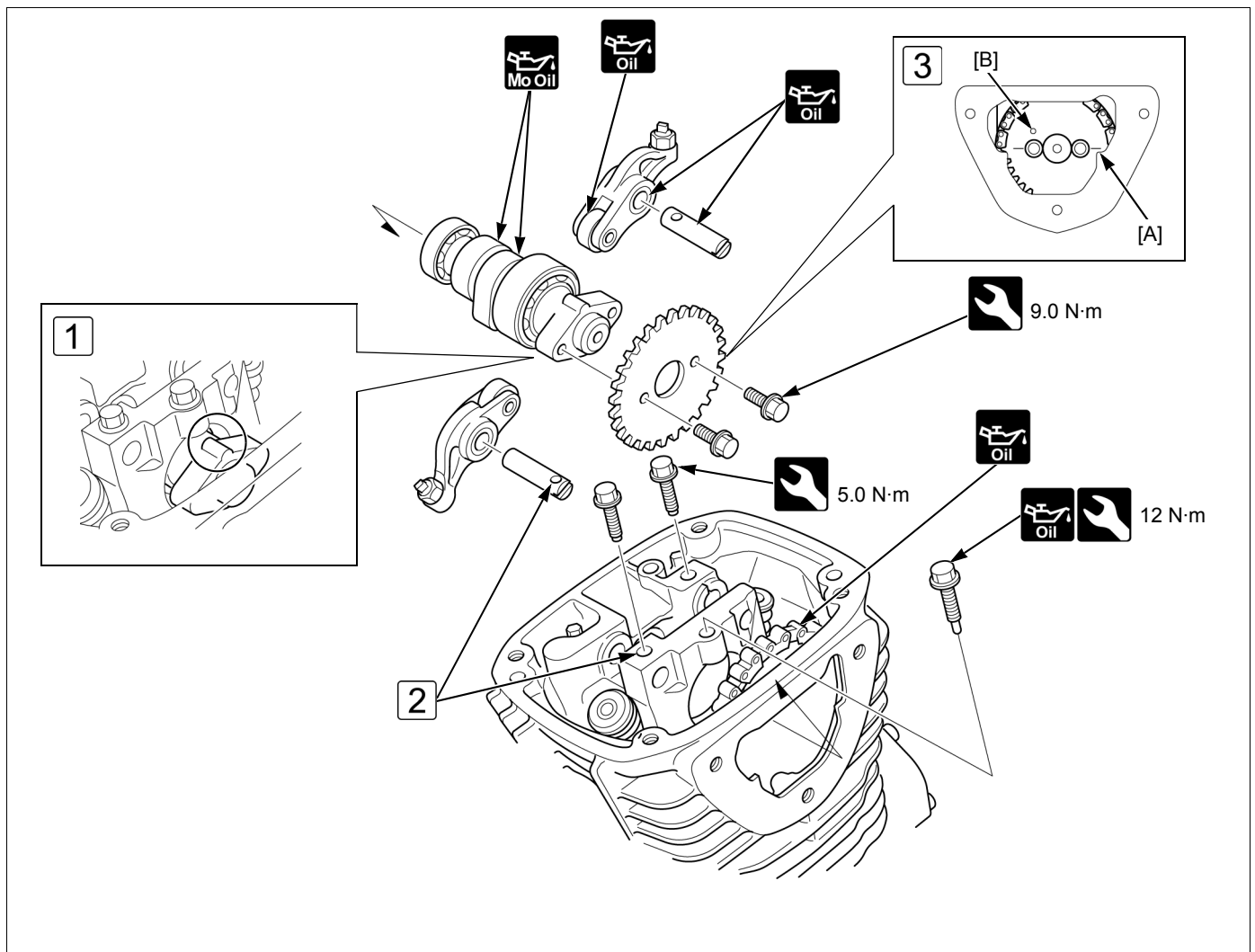

- 1 Install the camshaft with its flange tab facing up.
- 2 Insert the rocker arm shafts into the cylinder head in the position shown using a flat-tip screwdriver while aligning the bolt holes of the shaft with the bolt holes on the cylinder head.
- 3 The index lines on the cam sprocket are align with the cylinder head tabs [A]. Make sure that the mark [B] on the cam sprocket is in the position shown.



- Camshaft inspection