

REFACING

NOTE:

- Follow the refacing manufacturer's operating instructions.
- Be careful not to grind the seat more than necessary.

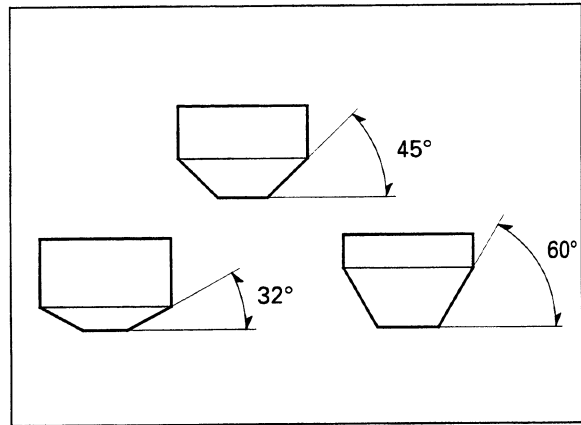

If the contact area is too high on the valve, the seat must be lowered using a 32° flat cutter.

If the contact area is too low on the valve, the seat must be raised using a 60° interior cutter.

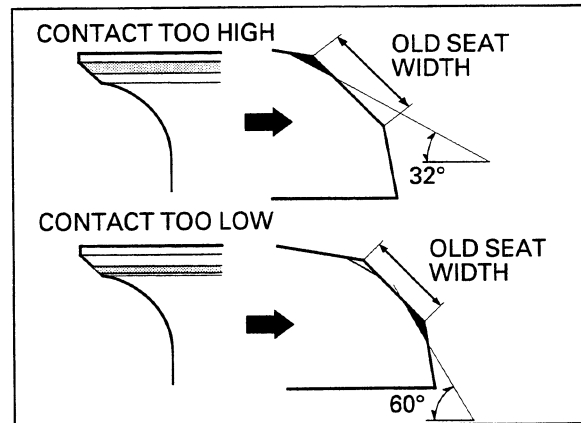

Using a 45° seat cutter, remove any roughness or irregularities from the seat.

TOOLS:

Seat cutter, 40 mm 07780-0010500
Cutter holder, 6 mm 07VMH-MBB0100

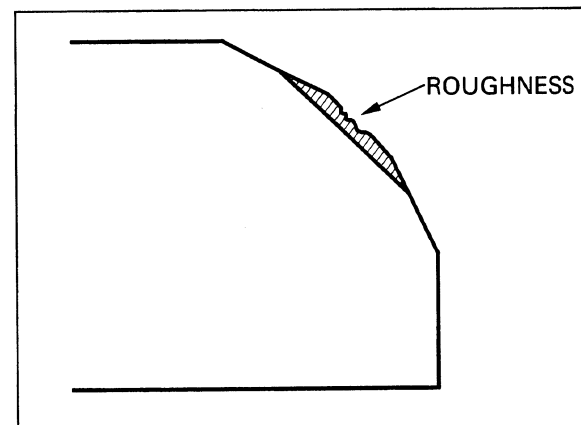

Using a 32° flat cutter, remove 1/4 of the existing valve seat material.

TOOLS:

Flat cutter, 38.5 mm (IN) 07780-0012400
Flat cutter, 35 mm (EX) 07780-0012300
Cutter holder, 6 mm 07VMH-MBB0100

