

CRANKCASE ASSEMBLY

Apply sealant to the crankcase mating surfaces as shown.

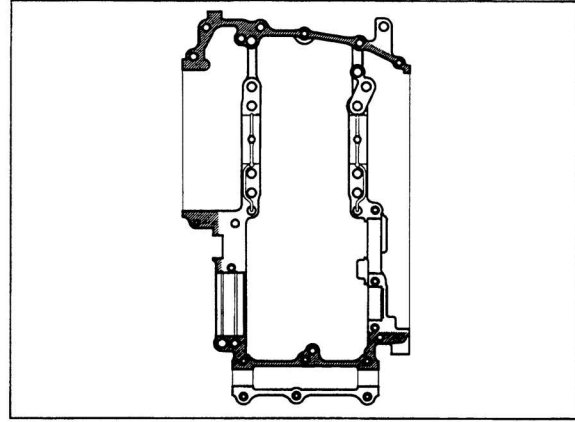

Install the dowel pins and oil orifices.

Apply molybdenum oil solution to the main journal bearing surfaces on the lower crankcase.

Install the lower crankcase onto the upper crankcase, aligning the shift forks with the gear shifter grooves.

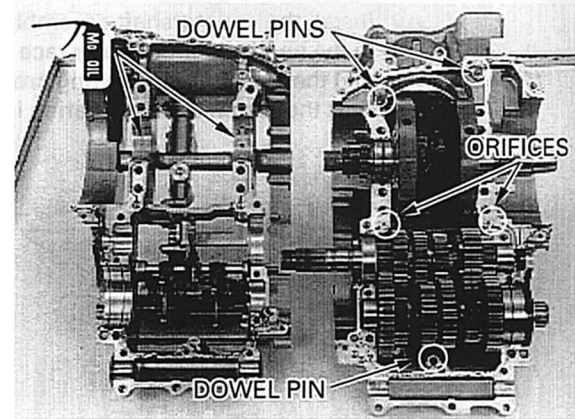

Apply oil to the 10 mm special bolt threads and seating surfaces.

Install the eight 10 mm bolt, six 8 mm bolts and two 6 mm bolts, and tighten them in a crisscross pattern in 2 or 3 steps.

TORQUE: 10 mm bolt : 42 N·m (4.3 kgf·m , 31 lbf·ft)

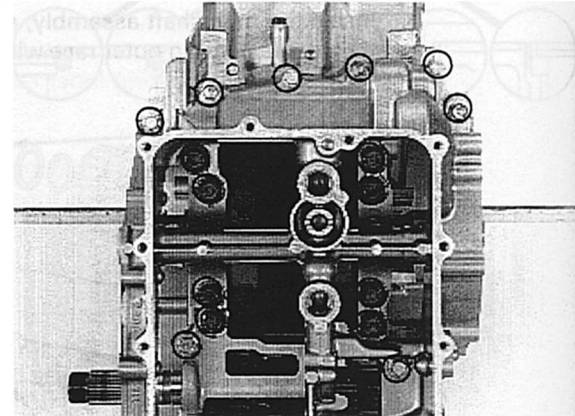

Install the 10 mm bolt, nine 8 mm bolts and two 6 mm bolts, and tighten them in a crisscross pattern in 2 or 3 steps.

TORQUE: 10 mm bolt : 39 N·m (4.0 kgf·m , 29 lbf·ft)

